

900W 10KV 耐压, 高電力抵抗器  
 900W, 10kV INSULATION  
 CHASSIS MOUNTING NON-INDUCTIVE  
 HIGH POWER RESISTORS,  
 WATER COOLING

## RPK900L



### 特長・用途

SOT227 型、接地耐電圧 10KVAC、定格電力 900W、水冷など放熱シャ  
 ーシ取付方式の RPK900L 高電力抵抗器。  
 コロナ放電開始電圧は 7kV-50kHz、小型ですから、直列インダクタンスは少  
 なく、高圧パルス回路、高周波回路に最適。  
 2 個の M4 ねじ簡単に取り付けることが可能。  
 抵抗器の高さは端子面で 12mm ときわめて低く小型。  
 端子の数は、2 本、端子数を変更する場合の形名呼称は、工場にお問い合  
 わせください。  
 高圧パルス発生回路、高圧パルス電源デバイダ抵抗器、パワーエレクトロニク  
 ス機器のフィルタ抵抗、インバータのブリーダ抵抗、高圧電源分圧抵抗

### Features and Applications

Small size SOT227, 900W high power resistor. Attaching  
 with a large forced air-cooled heat sink or liquid-cooling  
 would be necessary for high power operation.  
 Rated power is 900W with 10kV - 50Hz insulation voltage  
 and 7kV - 50kHz corona discharge.  
 M4 screw terminals, very low series inductance and  
 capacitance.  
 Higher density packing, vibration-proof and perfect heat  
 dissipation are available.  
 Applications include charge / discharge resistors, voltage  
 divider of the high voltage pulse source for X-ray CT, MRI,

### 外形寸法と材質, Dimensions and Materials

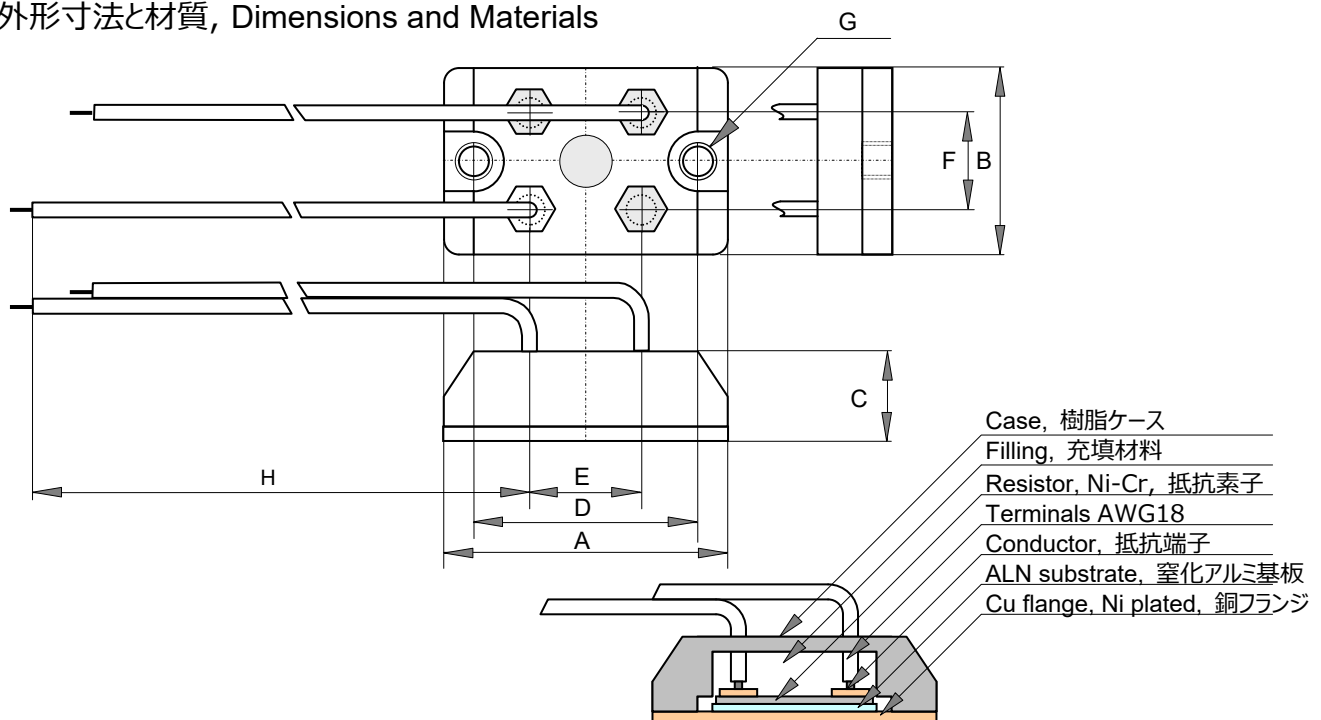

|   | (mm)                | (inch)                 |
|---|---------------------|------------------------|
| A | 38+/-0.5            | 1.50+/-0.02            |
| B | 25+/-0.5            | 0.98+/-0.02            |
| C | 12+/-0.5            | 0.47+/-0.02            |
| D | 30+/-0.2            | 1.18+/-0.008           |
| E | 15+/-0.5            | 0.59+/-0.02            |
| F | 13+/-0.5            | 0.51+/-0.02            |
| G | 2 - 4.20+/-0.1 dia. | 2 - 0.165+/-0.004 dia. |
| H | 250+/-10            | 9.8+/-0.4              |

## 900W 10KV 高耐压, 高電力抵抗器

900W 10KV CHASSIS MOUNTING NON-INDUCTIVE HIGH POWER RESISTORS

RPK900L

## 品目番号, Ordering Information

|         |           |      |        |        |
|---------|-----------|------|--------|--------|
| RPK900L | C         | 101  | J      | Z00    |
| RPK900L | C (50ppm) | +E24 | J (5%) | Z00    |
|         |           |      |        | (RoHS) |
|         |           |      |        | box    |

Resistance value is available following modified E24, +E24. Another is available optionally.

|     |     |     |     |     |     |     |     |     |     |     |     |     |     |
|-----|-----|-----|-----|-----|-----|-----|-----|-----|-----|-----|-----|-----|-----|
| 1.0 | 1.1 | 1.2 | 1.3 | 1.5 | 1.6 | 1.8 | 2.0 | 2.2 | 2.4 | 2.5 | 2.7 | 3.0 | 3.3 |
| 3.6 | 3.9 | 4.0 | 4.3 | 4.7 | 5.0 | 5.1 | 5.6 | 6.2 | 6.8 | 7.5 | 8.0 | 8.2 | 9.1 |

## 性能仕様, Specifications and Performances

|          |                       | Conditions                      |  |
|----------|-----------------------|---------------------------------|--|
| 定格電力     | Rating Power          | 900 Watts                       | At flange temperature -55 °C to +25 °C   |
| 熱抵抗      | Thermal Resistance    | 0.10 °C/W                       | Between resistor to flange   |
| 製作抵抗値範囲  | Resistance Range      | 10 Ω to 1K Ω                    |  |
| 公称抵抗値    | Nominal Resistance    | Modified E24                    | Any value, option  |
| 抵抗温度係数   | TCR                   | +/- 50 ppm/°C (C)               | For -55 to +155 °C   |
| 抵抗値許容差   | Tolerance             | +/-5% (J)                       | available +/- 1% (F) option  |
| 動作温度範囲   | Operation Temp. Range | -55 °C - +155 °C                |  |
| 最大動作電圧   | Limiting Voltage      | 1000V or $E = \sqrt{P \cdot R}$ |  |
| 絶縁耐電圧    | Withstanding Voltage  | 10,000 VAC                      | 60 seconds - 0.5mA - 50Hz  |
| 部分放電開始電圧 | Partial discharge     | 7,000 V - 50kHz                 | Starting voltage, typical  |
| キャパシタンス  | Capacitance           | 13.1 pF                         | Parallel capacitance at 10MHz, short wire leads                                      |
| インダクタンス  | Inductance            | 13.7 nH                         | Series inductance at 10MHz, short wire leads   |
| 負荷寿命     | Load Life             | +/- (1.0 % + 0.05 Ω)            | 25°C, 90min.ON, 30min.OFF, 1000hours.  |
| 耐湿性      | Humidity              | +/- (1.0 % + 0.05 Ω)            | 70°C, 90 to 95%RH, DC0.1W, 1000hours.  |
| 温度サイクル   | Temperature Cycle     | +/- (1.0 % + 0.05 Ω)            | -55°C, 30 min., +125°C 30min., 20cycles. (-55°C, 30 min., +120°C, 30min., 5 cycles.) |
| 短時間過負荷   | Short Time Overload   | +/- (5.0 % + 0.05 Ω)            | Rating watt×1.5, 5seconds, with heat sink.   |
| 絶縁抵抗     | Insulation Resistance | Over 1000 meg Ω                 | Between terminals and flange.  |
| 耐振性      | Vibration             | +/- (0.25 % + 0.05 Ω)           |  |
| 重量       | Weight                | 38 grams                        | Without wire terminals   |

## 負荷軽減, Derating Curve, RPK900

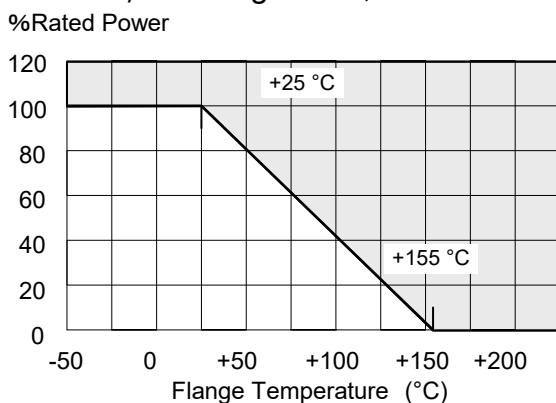

## 温度上昇, Temperature Rise, RPK900L

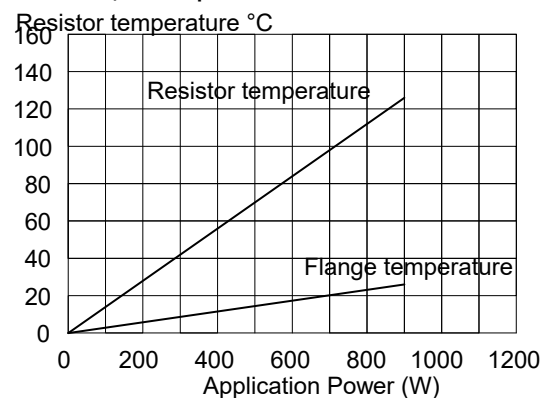

900W 10KV 耐圧, 高電力抵抗器

900W 10KV CHASSIS MOUNTING NON-INDUCTIVE HIGH POWER RESISTORS

RPK900L

パルス動作の参考資料, Pulse Operation

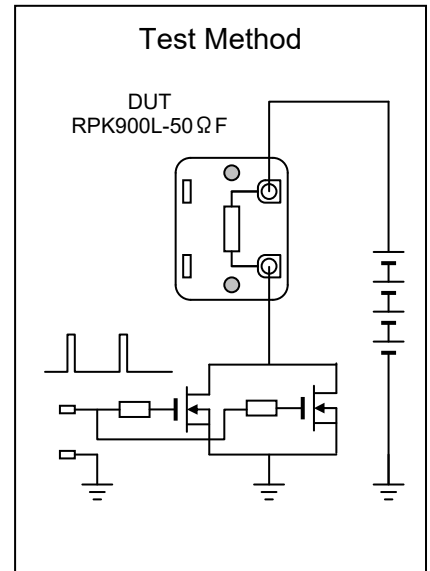
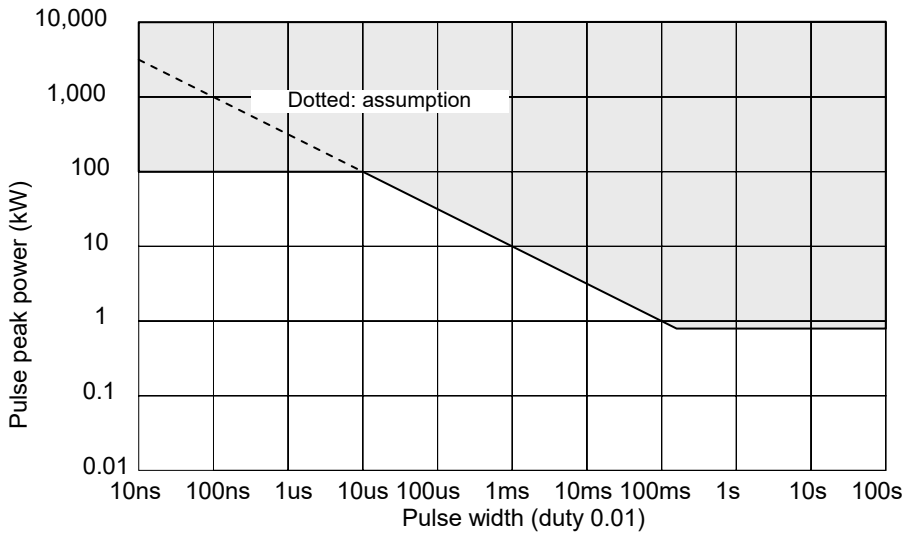

デューティ 0.01 の連続パルスにおける、許容尖頭電力の目安。この曲線は、抵抗値、パルス繰返周波数、デューティ、動作温度によって変化するので、実際の機器に実装し寿命試験を行うよう推奨します。破線は、推定領域。

Above drawing shows allowable pulse peak power that obtained by actual breaking test of RPK900L-10Ω-J, and shows the result of double safety factor. The test was performed by observation of small resistance change after application of continuous pulse, that is rectangular waveform and 0.01 duty.

Since the pulse durability is moved by the resistance, the pulse waveforms and type of pulse source, constant voltage source or current source, please test carefully for long terms on actual electronics when operating the resistor by the pulse of the peak power exceeding rated power.

応用, APPLICATIONS

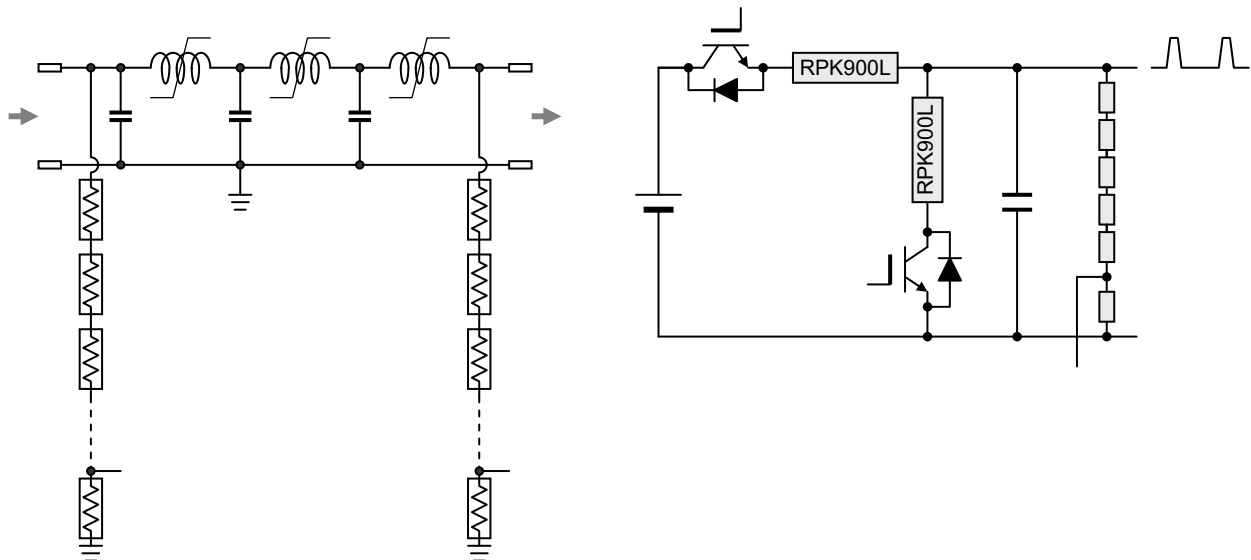

Typical High speed pulse power generator and water cooling resistor, RPK900L