

表面実装35W高電力抵抗器

TO263 SURFACE MOUNT  
35W HIGH POWER RESISTORS  
RNP-20D, RNP-20E, RNP-20F

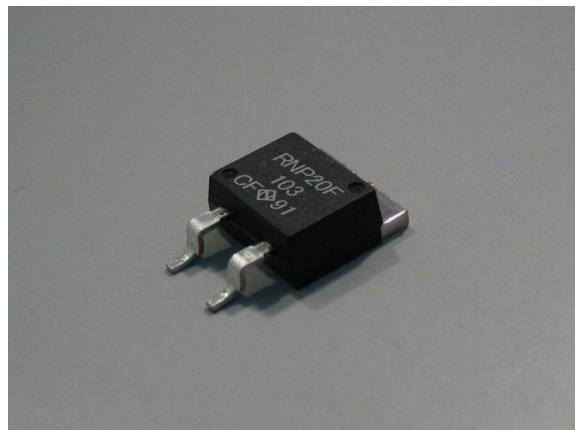

特長 用途

ニッケルめっき (RNP-20D)、半光沢すずめっき (RNP-20E, RNP-20F) のフランジ、TO263(D2PAK)、定格電力 35W 高電力抵抗器。  
DC から数 100MHz にて誘導性、容量性ともきわめて少ない特長があり、50Ω から 100Ω では 1GHz 付近まで平坦な特性を示し、高周波回路、高速パルス回路に最適な抵抗器。  
独自の内部構造によって、最高使用温度 155°C の抵抗体とフランジ間の熱抵抗を 3.3°C/W まで減少させ、優秀な熱放散特性。  
フランジと回路は、耐圧 2KV で絶縁。  
電力制御機器、インバータ、UPS、モータ制御、精密プログラム電源、定電流電源、電子負荷、高周波電源、高周波増幅器、50Ω ターミネーション。

Features and Applications

35W high power resistors in TO263 (D2-PAK) style surface mount mold package with Nickel plated (RNP-20D), matte Tin plated (RNP-20E, RNP-20F) flange.  
Non-inductive design suits high frequency applications and high-speed pulse circuits.  
Low, 3.3 deg C/W heat resistance from resistor hot spot to flange and long life performance are presented with thin film metallization technology.  
Wide, 10 mΩ to 51K Ω resistance range, non-inductive impedance characteristic and heat extracting through insulated metal flange aids circuit designers.  
Applications for UPS, power unit of machines, motor control, drive circuits, automotive, measurements, industrial computers and high frequency electronics.

外形寸法、Dimensional Specifications (mm)

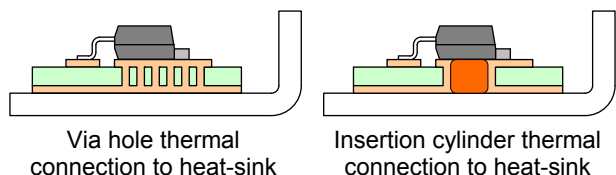
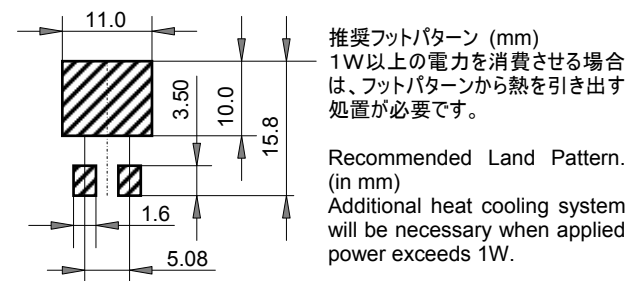
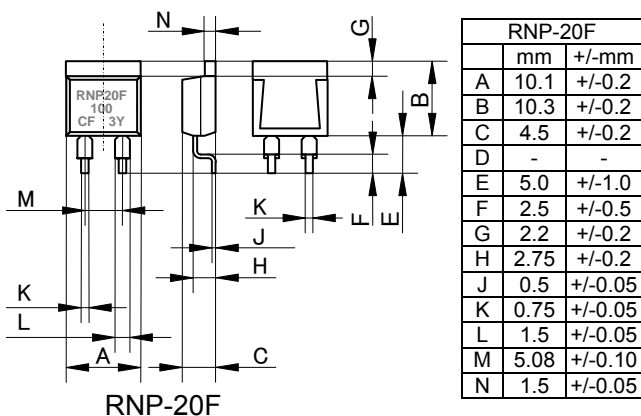
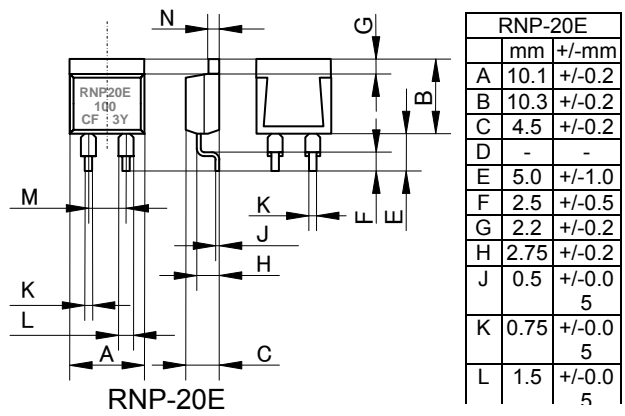
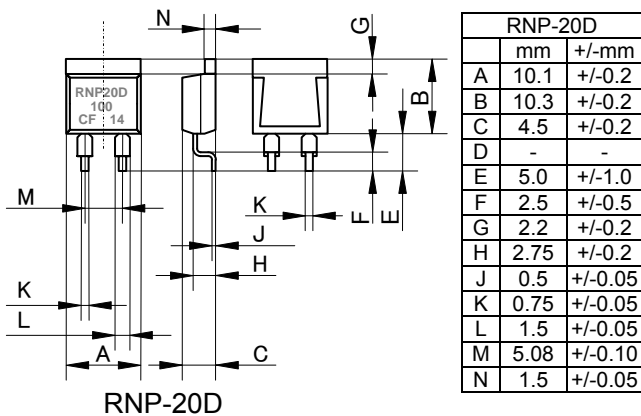

表面実装35W高電力抵抗器

TO263 SURFACE MOUNT 35W HIGH POWER RESISTORS

RNP-20D, RNP-20E, RNP-20F

構造材料とリフロー温度

Materials and Reflow Temperature

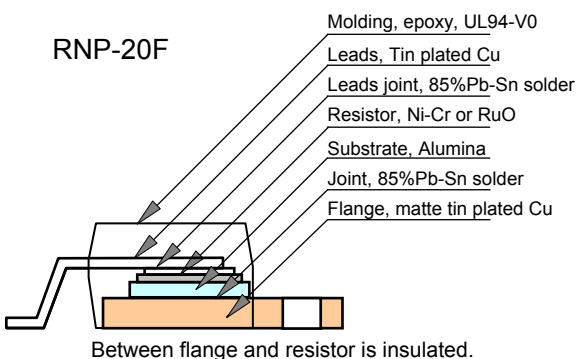
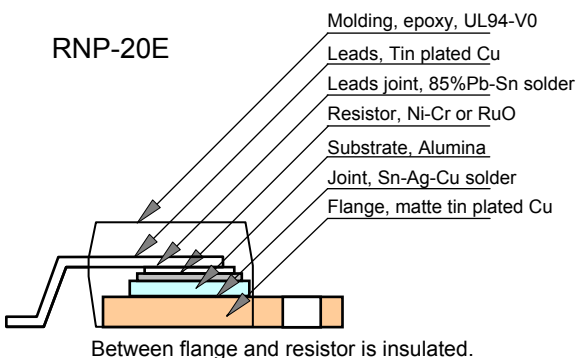
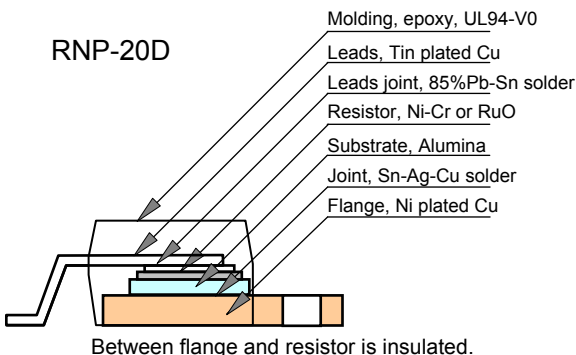

プリント基板に実装する場合は、その他の表面実装部品と一緒にリフローはんだを行うことを避けてください。その他の部品を実装した後、SACはんだでプリントした回路に、先端温度、300-350 deg Cのはんだこてで、抵抗器のフランジを 270+/-10°C、20-30 秒加熱しフランジのはんだ付を行う必要があります。はんだ付には、ソルダーフラックスを使用する必要があります。When joint on printed circuit board, reflow soldering by furnace with another parts shall not be recommended. After mounting another parts and after pre-coating solder on to land pattern, dip flange and leads in to soldering resin, place RNP-20D resistor on the land pattern, and heat flange for 20-30 seconds by soldering iron which iron tip temperature is 300-350 deg C. Flange temperature shall be in 270+/-10 deg C for 30 seconds. A better result will be obtained if flange is pre-coating solder. Please note using soldering flux and large caloric capacity.

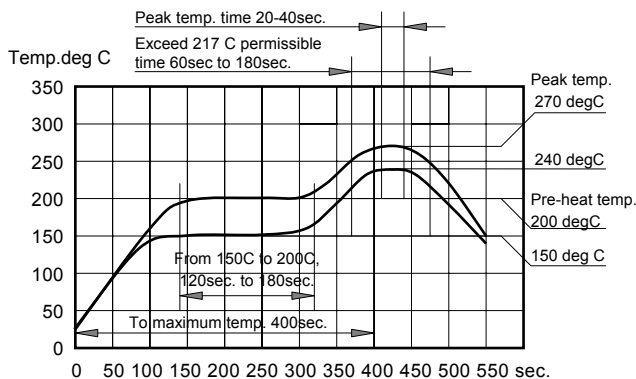
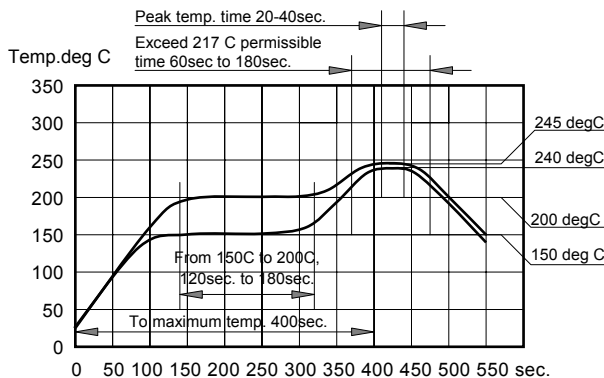

形名称呼 Ordering Information

Type RNP-20F	TCR A	Resistance 1R0	Tolerance F	Code Z00	Z: RoHS Tube/50pcs Tape/500pcs
RNP-20D	H(>250ppm)	R02 to 51K	J (5%)	Z00(Bulk)	
RNP-20E	A(100ppm)	E24+	F (1%)	Z01(Tape)	
RNP-20F	C(50ppm)	R01-1% is option			

Resistance value (\*) is available following modified E24 as +E24.

1.0	1.1	1.2	1.3	1.5	1.6	1.8	2.0	2.2	2.4	2.5	2.7	3.0	3.3
3.6	3.9	4.0	4.3	4.7	5.0	5.1	5.6	6.2	6.8	7.5	8.0	8.2	9.1

表面実装35W高電力抵抗器

TO263 SURFACE MOUNT 35W HIGH POWER RESISTORS

RNP-20D, RNP-20E, RNP-20F

仕様	Specifications	RNP-20D, RNP-20E, RNP-20F			Test Conditions
形式	Type	RNP-20D, RNP-20E, RNP-20F			Test Conditions
定格電力	Rating Power	35 Watt			-55 deg C to 25 deg C flange temperature
定格電力	Rating Power	1 Watt			Attached on simple foot print.
熱抵抗	Heat Resistance	3.3 deg C/W			Resistor hot spot to flange
抵抗値	Resistance Range	0.02-0.091Ω	0.1-9.1Ω	10-51KΩ	Note 2
公称抵抗値	Nominal	E6	E24	E24	Include 2.5, 4.0, 5.0, 8.0 and 16
TCR(ppm/deg C)	TCR (ppm/deg C)	250(H)	100 (A)	50 (C)	Note 3.
抵抗値許容差	Tolerance	5%(J)	1% (F) 5% (J)	+/-1% (F)	1% tolerance at 0.01-0.091 Ω are available.
等価並列容量	Capacitance	1.44pF			Equivalent parallel capacitance.
等価直列誘導	Inductance	8.38nH			Equivalent series inductance
使用温度範囲	Operation Temp.	-55 deg C to +155 deg C			
最高使用電圧	Operating Volt.	Either 500V or $\sqrt{P \cdot R}$			P is rating power and R resistance
絶縁耐電圧	Withstanding Volt.	2000 VAC			Terminal and flange, 60 seconds. 1mA
定格負荷寿命	Load Life	+/- 1.0 %			25 deg C, 90 min.ON, 30 min. OFF, 1000h.
耐湿性	Humidity	+/- 1.0 %			40 deg C, 90-95%RH, DC 0.1W, 1000 hours.
温度サイクル	Temp. Cycle	+/- 0.25 %			-55 deg C, 30 min., +155 deg C, 30 min., 5cyc
はんだ耐熱性	Soldering Heat	+/- 0.1 %			350 +/- 5 deg C, 3seconds.
はんだ付性	Lead Solder ability	Over 95% of surface			230 +/- 5 deg C, 3seconds.
絶縁抵抗	Insulation Resistance	Over 1,000 Meg Ω			Between terminals and tab.
耐振性	Vibration	+/- 0.25 %			IEC60068-2-6, see note 4
難燃性	Flammability	UL94-V0			
重量	Weight	1.5 grams			

負荷軽減、Power Derating

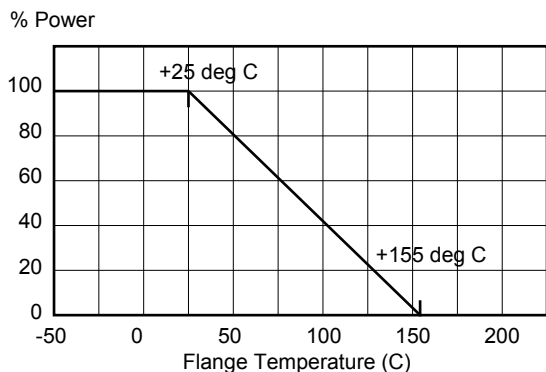

パルス負荷特性 Pulse Energy Durability

Pulse peak power (W) RNP-20F C100F, RNP-20D, RNP-20E

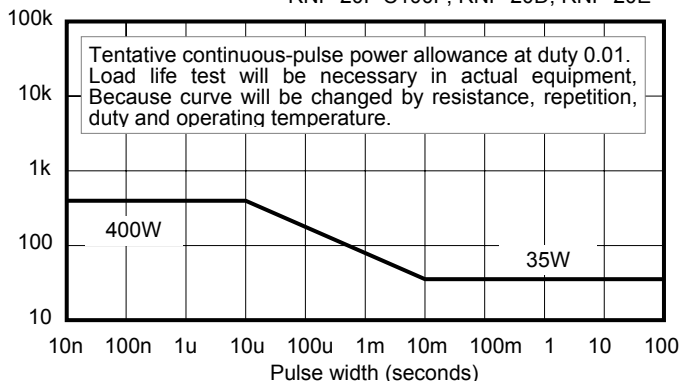

テーピング寸法、Tape Dimension

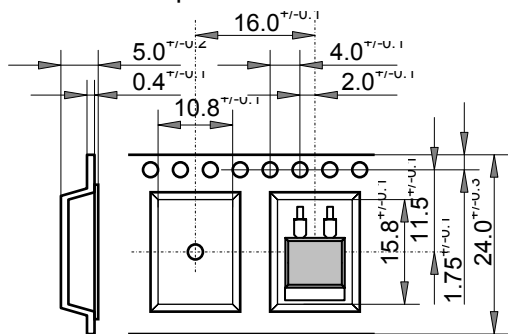

Reel Dimension

Outer diameter: 330 mm  
 Inner diameter: 100 mm  
 Width: 23.9 mm min. 27.4 mm max  
 Package quantity: 500pcs/13 inches reel

Note:

- (1) Flange insulation is not necessary between flange and heat-sink, flange and resistor is separated by alumina substrate.
- (2) Resistance measurement shall be made at terminal foot portion.
- (3) TCR of low resistance will be increased as 300ppm/0.02Ω, 200ppm/0.05Ω, 140ppm/0.1Ω and 80ppm/0.2Ω typically. Testing point is at 5.27mm from bottom of molding of terminals.
- (4) Test method is IEC60068-2-6, and specification is sine sweep wave form, 100Hz-2000Hz, 10 cycles, amplitude 0.75mm or 100m/s<sup>2</sup>, 90minutes. direction x-y z, Amplitude 0.75mm will be applied under break point Frequency (about 60Hz) and 100m/ s<sup>2</sup> over break point
- (5) Standard packaging is tape reel, a tape reel contains 500pcs. when small quantity, tube packaging will be used, the tube is made by RoHS PS/PE which contains 50pcs / tube.